

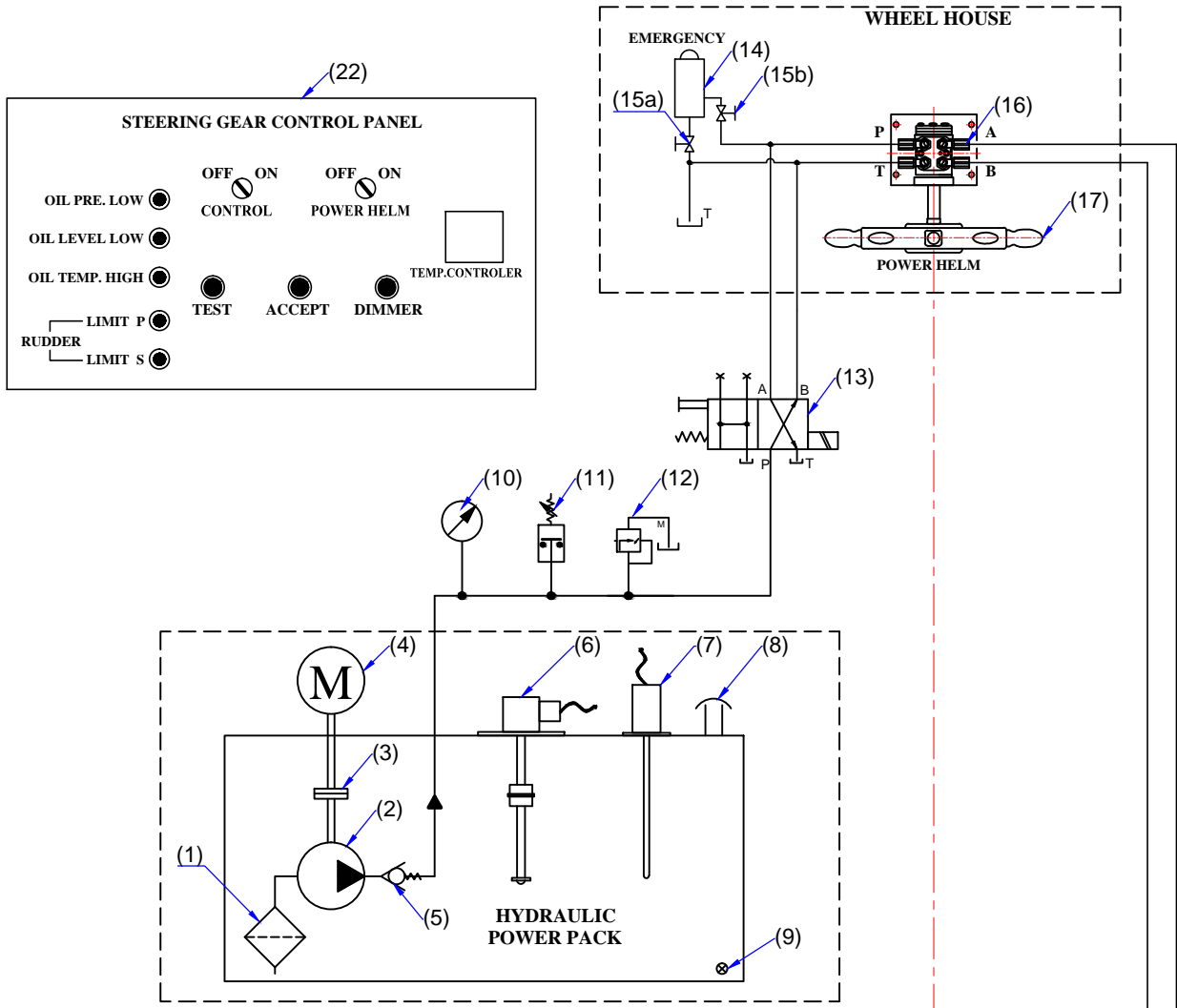

Electro - Hydro. Circuit of JumboZ-500E with Power Helm

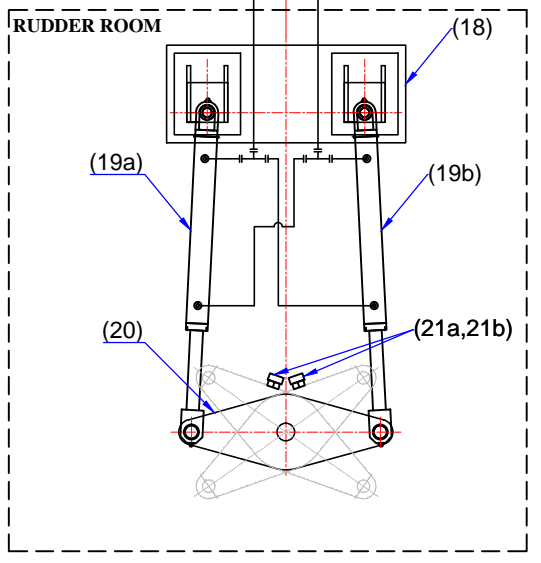

22	Electrical Panel
21a,21b	Mechanical Stopper (Yard Supply)
20	Tiller Arm
19a,19b	Hyd. Actuator JumboZ -500 IRS
18	Rear End Bkt.Assy.
17	Wooden Steering Wheel 27" OR SS Steering Wheel 24"
16	Power Helm
15a,15b	Ball Valve
14	Emergency Reservoir
13	Unloading Valve
12	Pressure Relief Valve
11	Pre.Switch.Low Pre.Alram
10	Pressure Gauge
9	Drain Plug
8	Filler Breather
7	Oil Temp. Sensor
6	Oil Level Sensor
5	Non-Return Valve
4	Electric Motor
3	Flexible Coupling
2	Hydraulic Pump
1	Suction Strainer
SI No.	Description



	MAC ♦ N ♦ HOM SYSTEMS KOCHI - 20	DESIGNATION	DWG. No.	DATE
		Schematic Circuit Diagram of JumboZ-500 with Power Helm	MHS-4192	03.10.2024